



SCHOLPP
Der Systemdienstleister®

S-TR

SCHOLPP Transportroller

S-TR

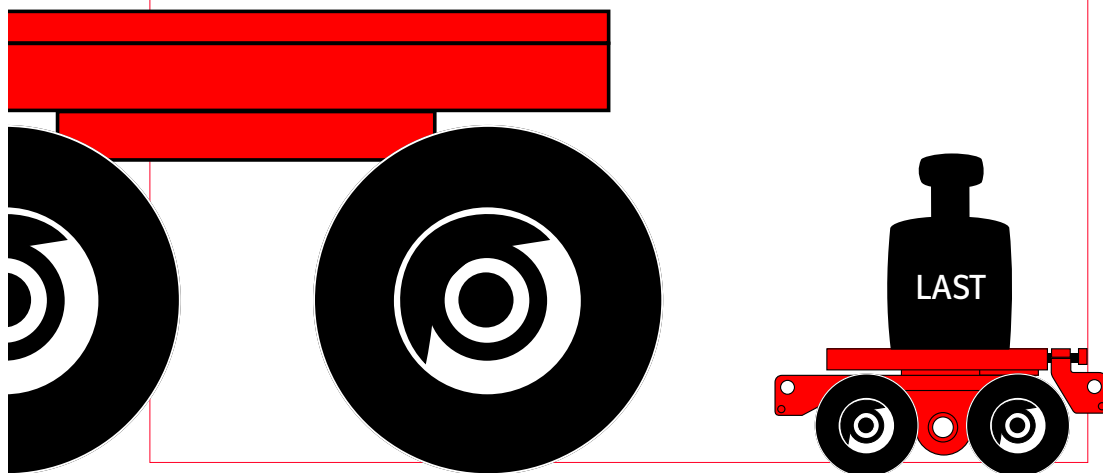



Transportroller	Seite	1	60 kN
-----------------	-------	---	-------

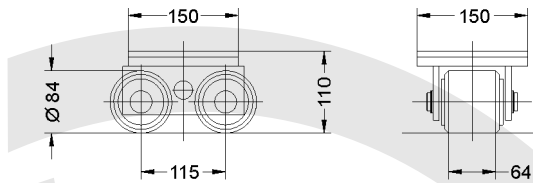

Fahrwerk (starr)
Nutzlast 30 kN / Paar
15 kN / Einzelement

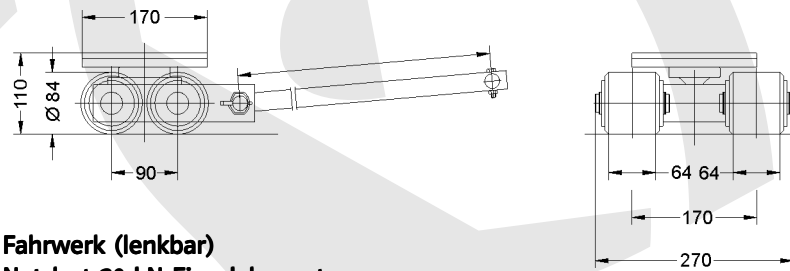

Fahrwerk (lenkbar)
Nutzlast 30 kN Einzelement

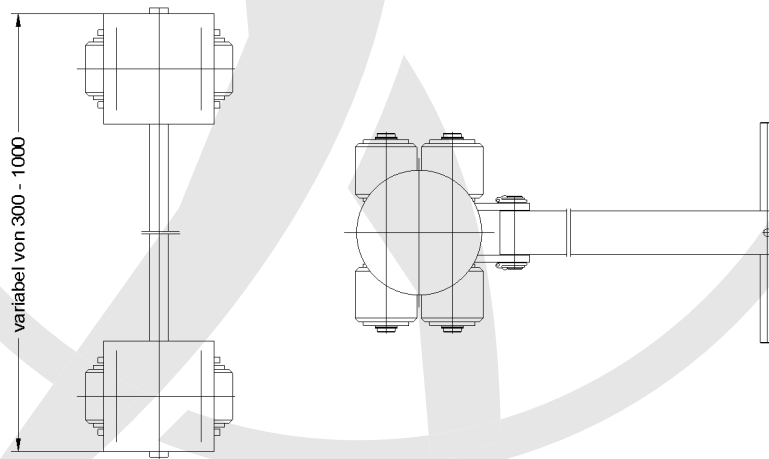

Fahrwerkssatz, Nutzlast 60 kN



Fahrwerk (starr)
Nutzlast 60 kN Einzelement

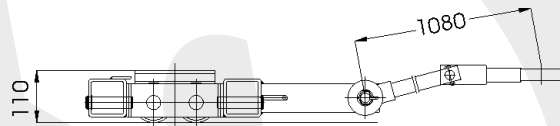

Fahrwerk (lenkbar)
Nutzlast 120 kN Einzelement

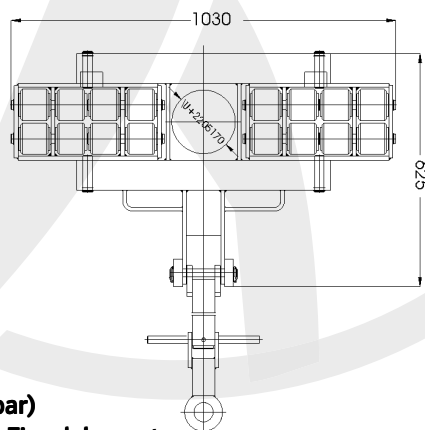
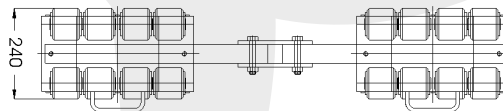

Fahrwerk (lenkbar)
Nutzlast 240 kN Einzelement



SCHOLPP
Der Systemdienstleister®





Transportroller	Seite	3	400 kN
-----------------	-------	---	--------

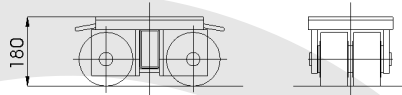

Fahrwerk (starr)
Nutzlast 100 kN Einzelement

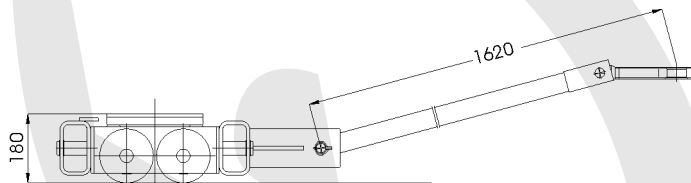

Fahrwerk (lenkbar)
Nutzlast 200 kN Einzelement

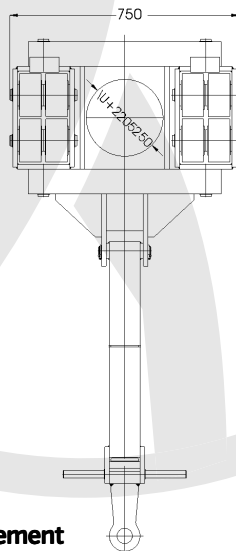
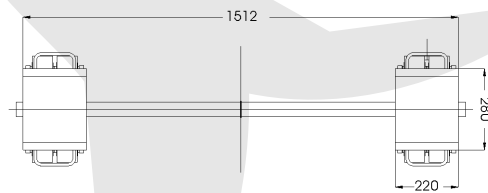

Fahrwerk (lenkbar)
Nutzlast 400 kN Einzelement



Dimensionen Einzelelement

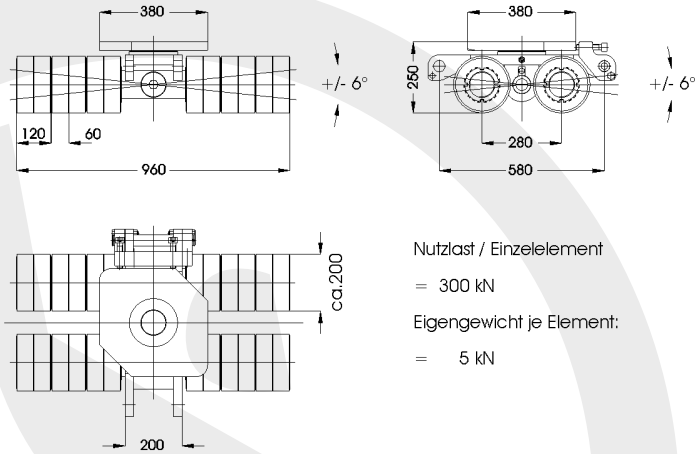

Systemskizze Elementanordnung

