

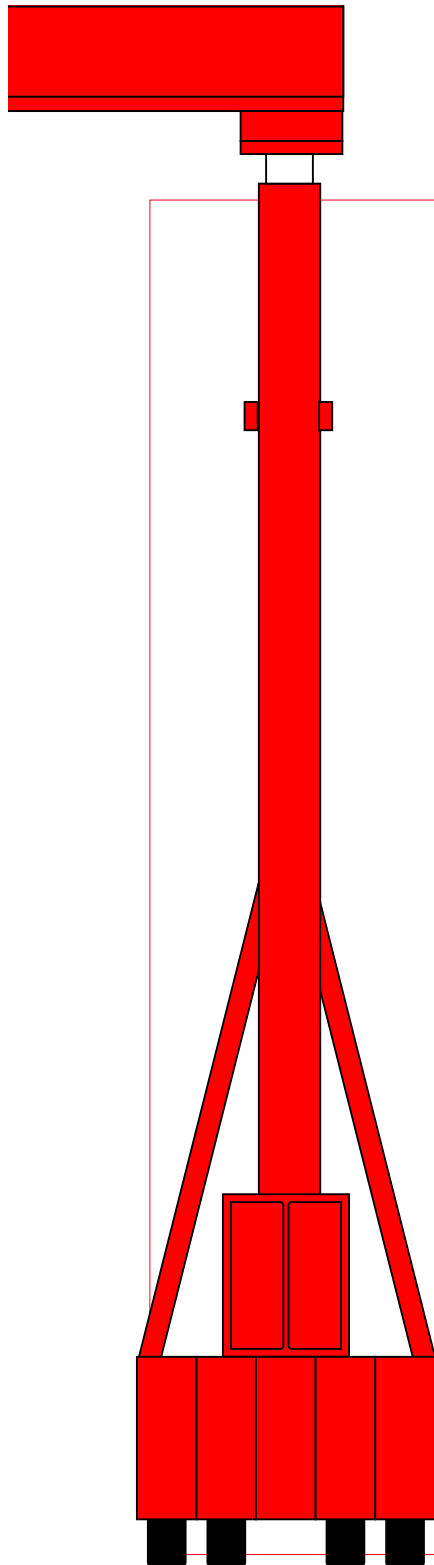

SCHOLPP
Der Systemdienstleister®

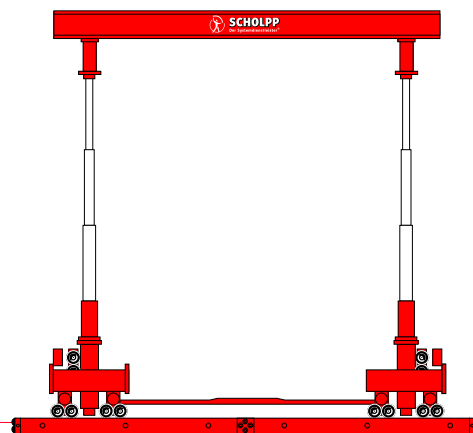

S-HG
SCHOLPP
Hydraulisches
Hubgerüst



S-HG

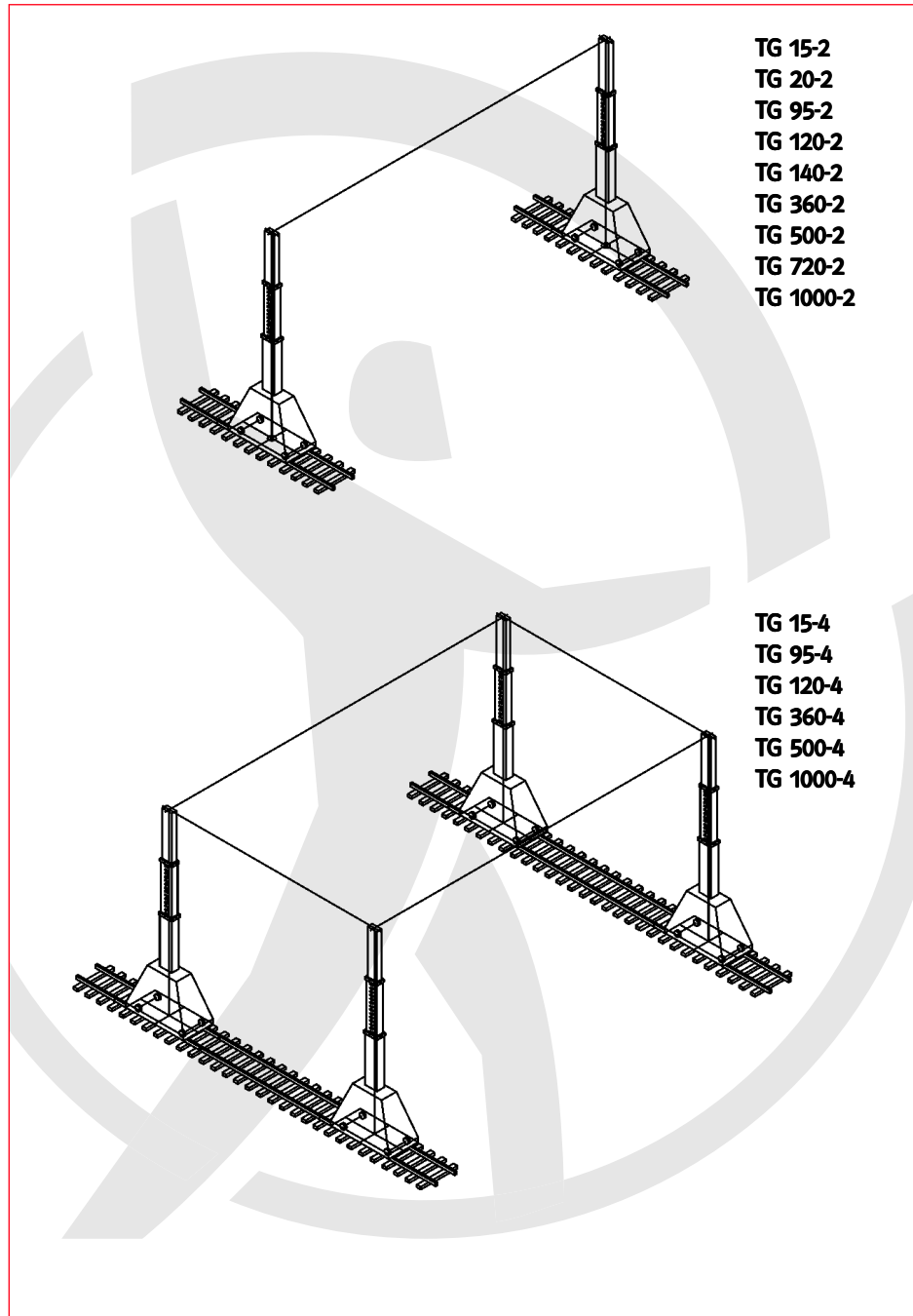



Hubgerüst eingefahren

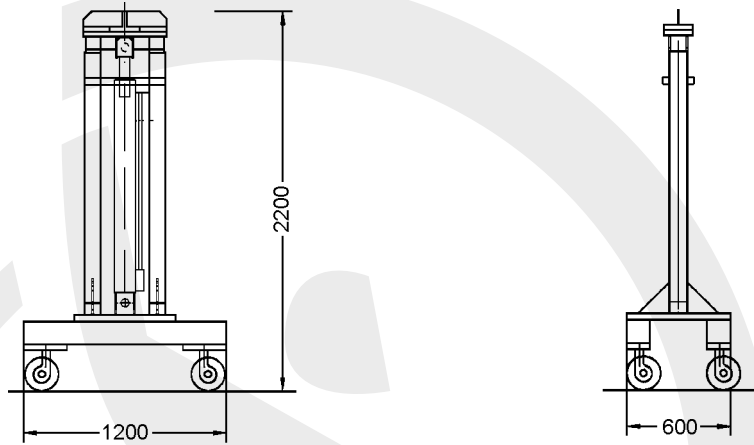

Hubgerüst ausgefahren

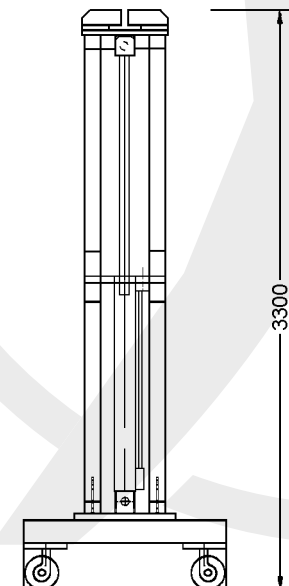

Infoline 01805 - 75 85 99



SCHOLPP
Der Systemdienstleister®

Hydraulisches Hubgerüst

Seite

3

200 kN (TG 20)

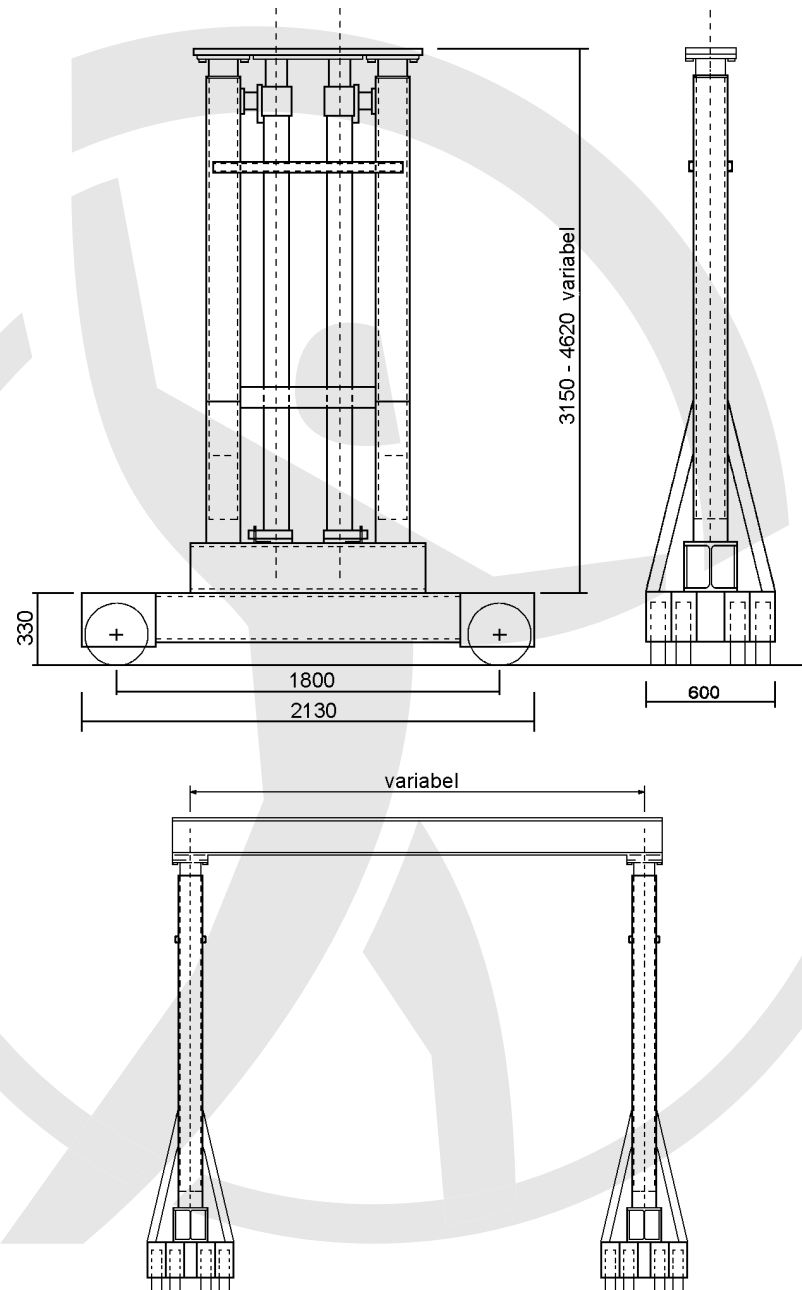

Stand 2007

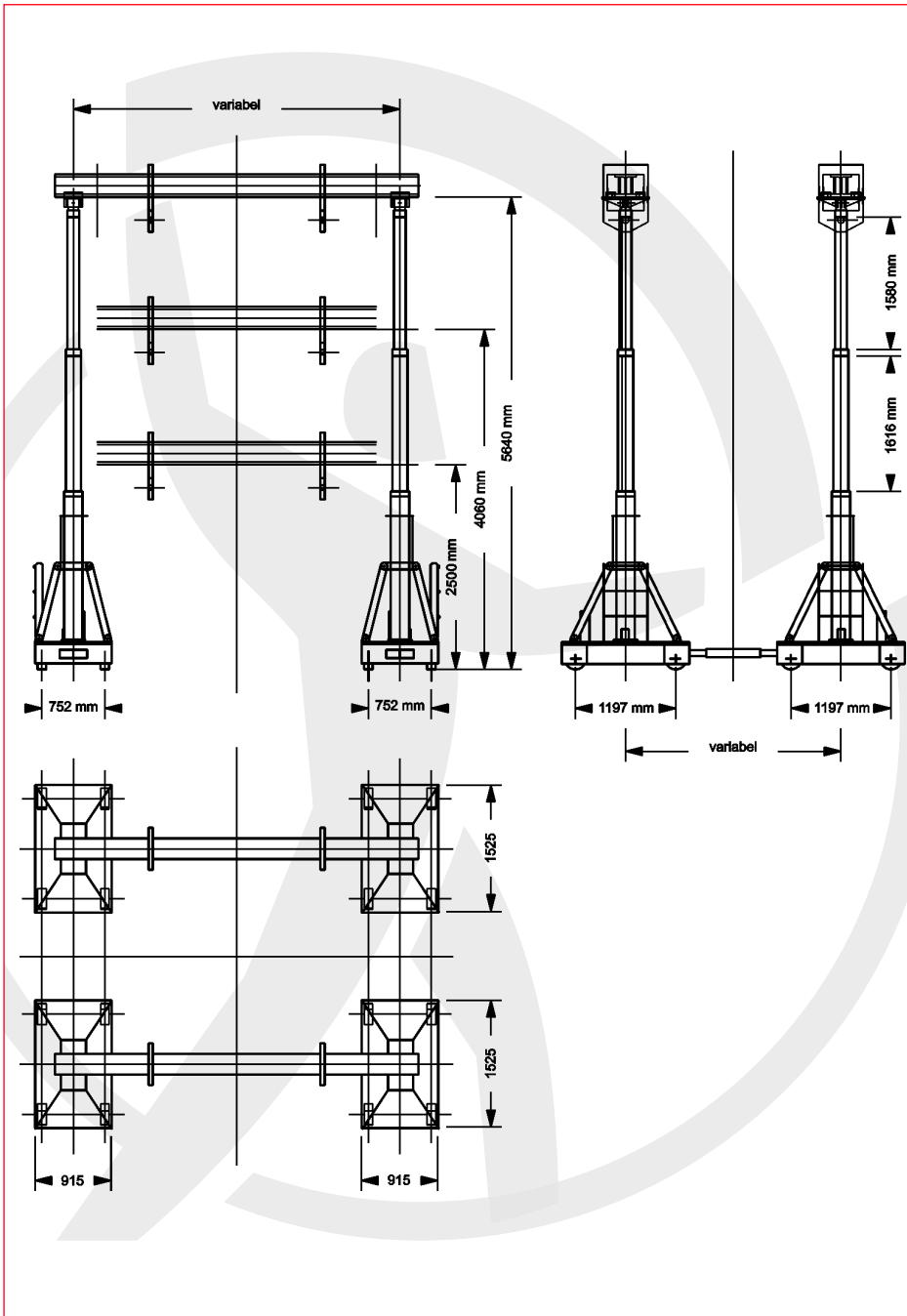

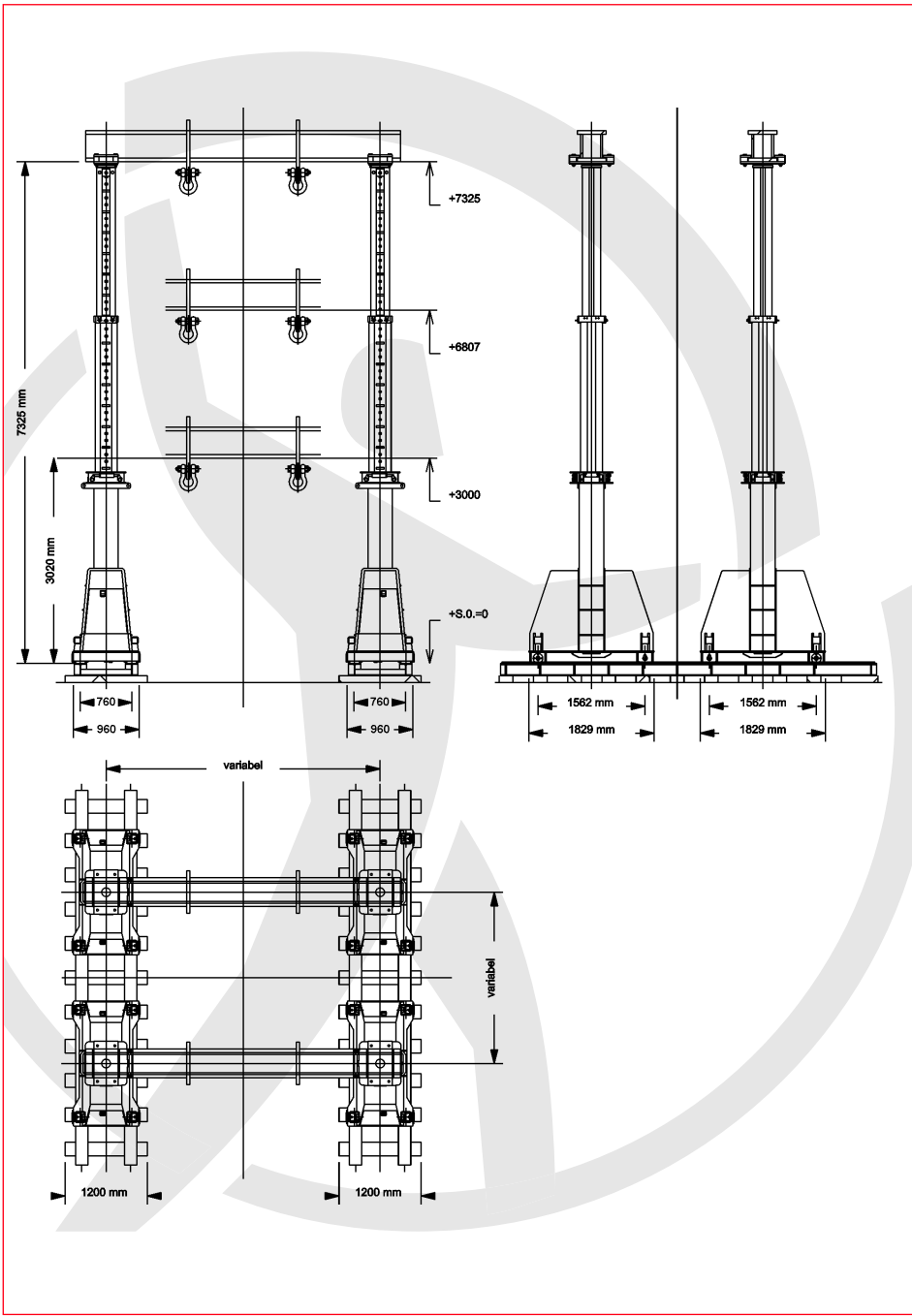

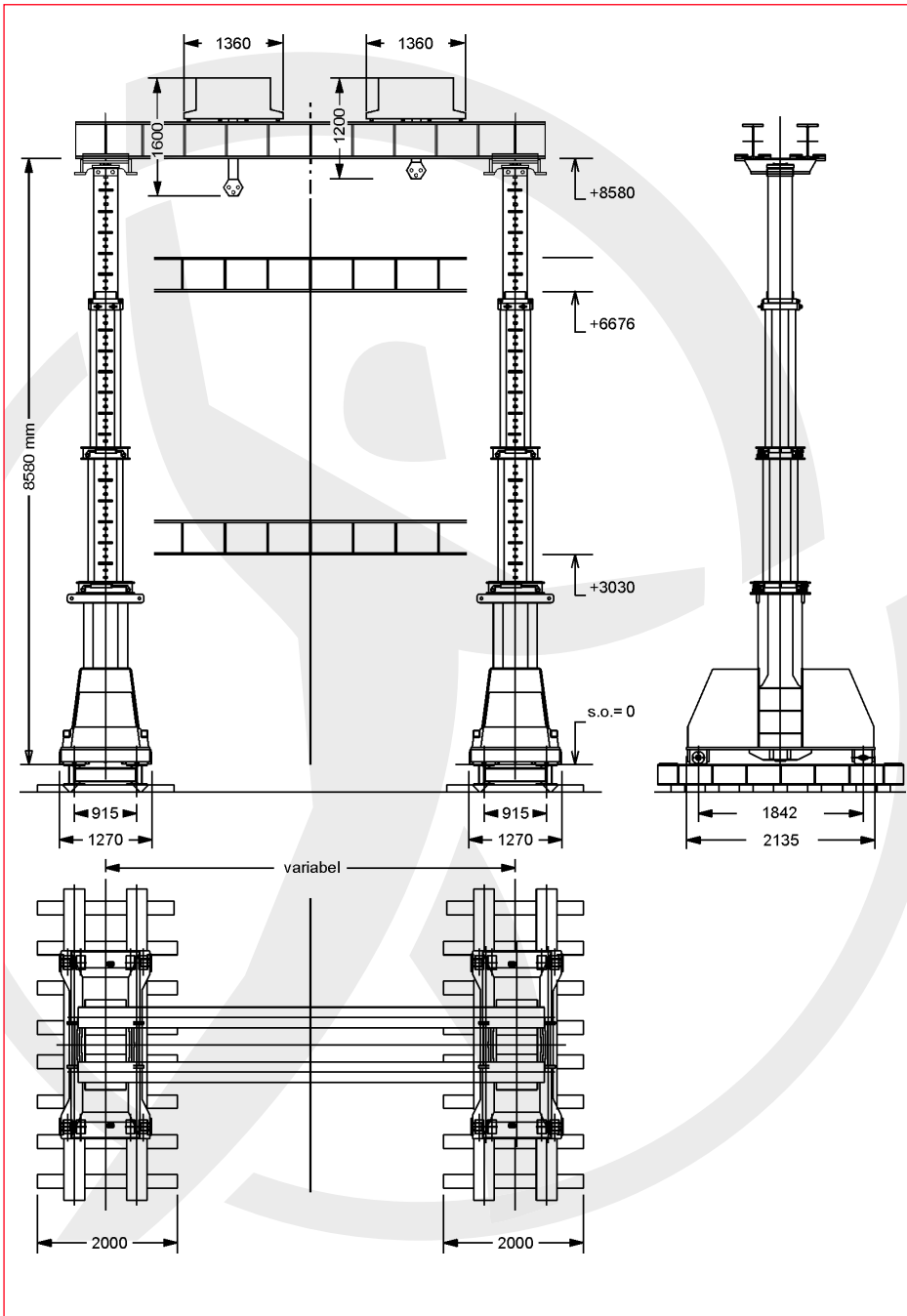

Infoline 01805 - 75 85 99



SCHOLPP
Der Systemdienstleister®

Hydraulisches Hubgerüst

Seite

7

3600 kN (TG 360-2/4)

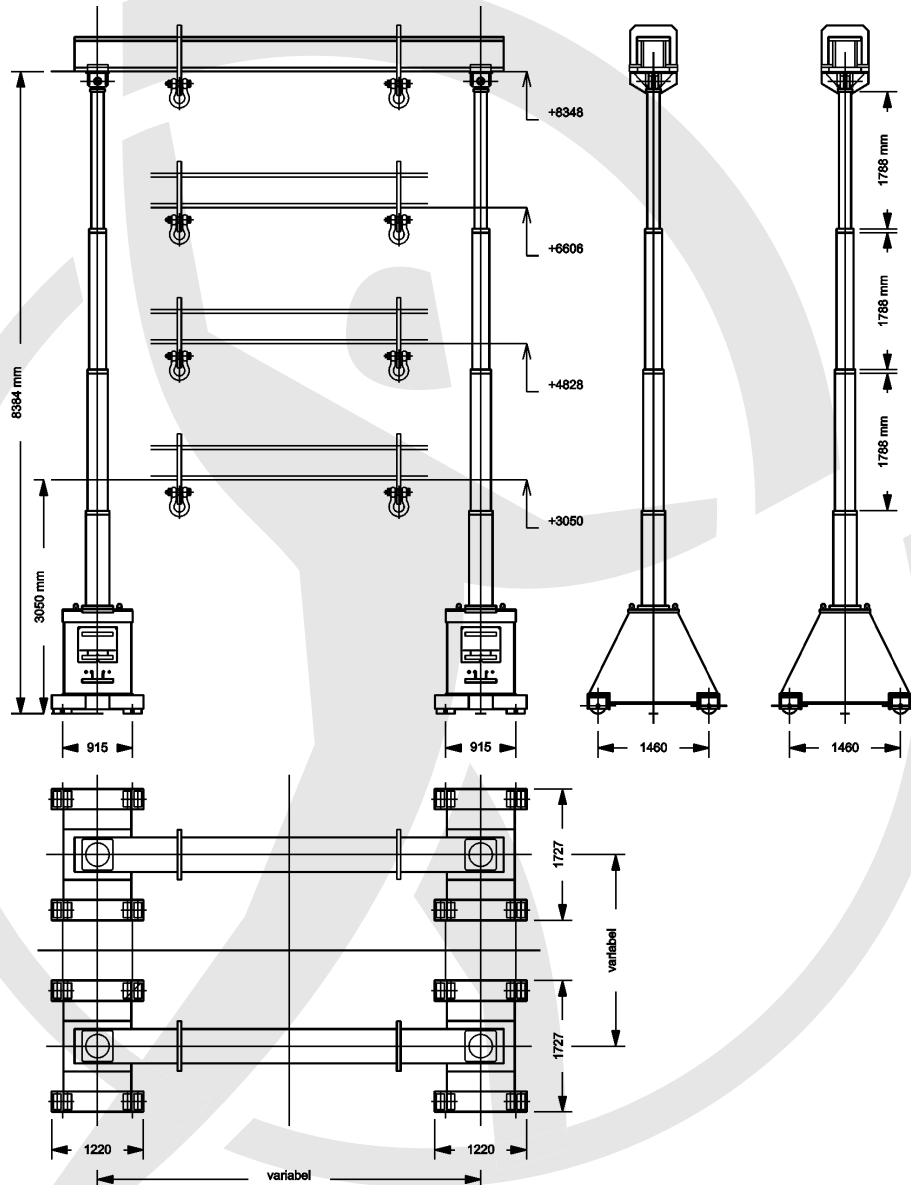

Stand 2007



SCHOLPP
Der Systemdienstleister®

SCHOLPP

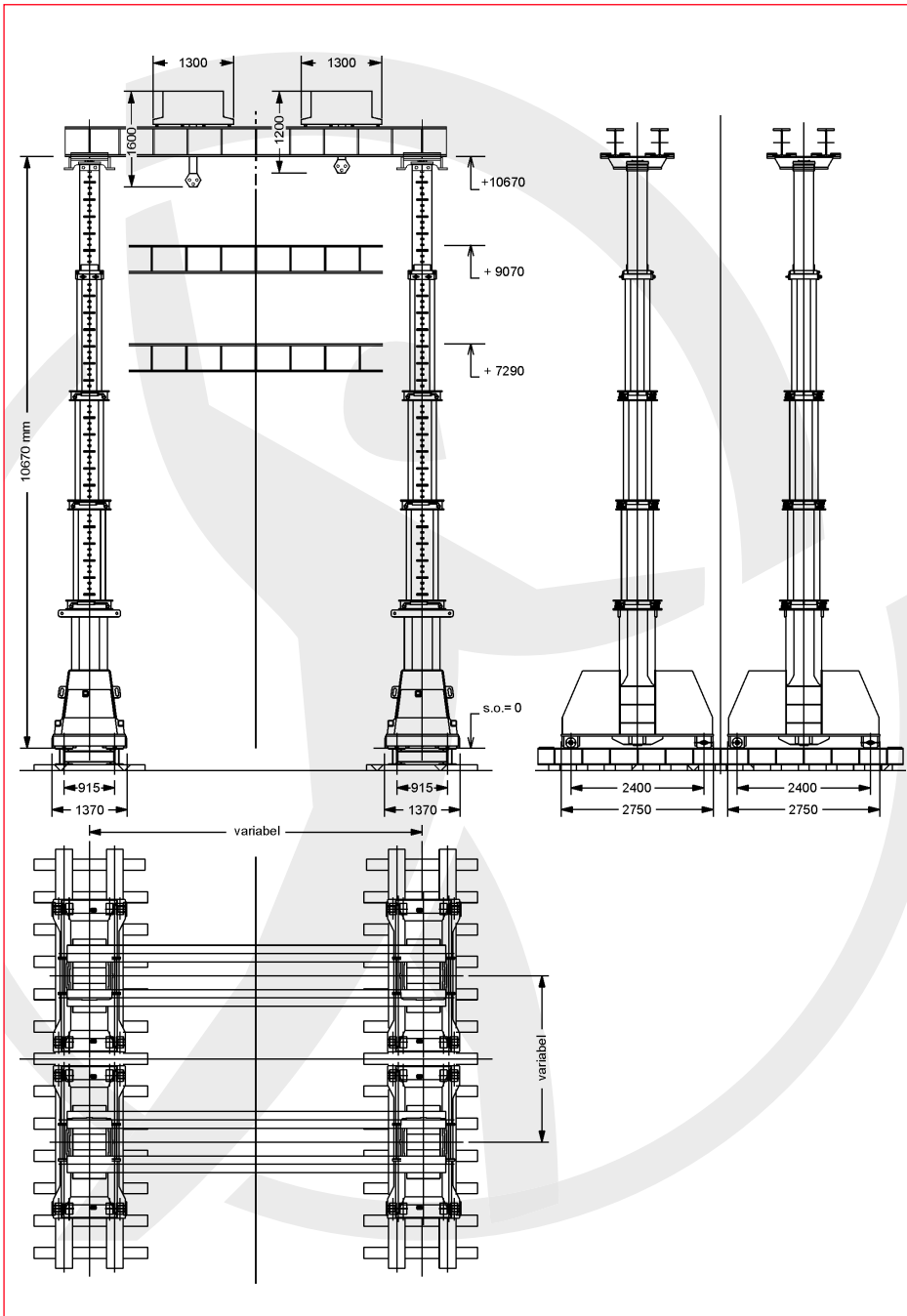

Der Systemdienstleister
6100

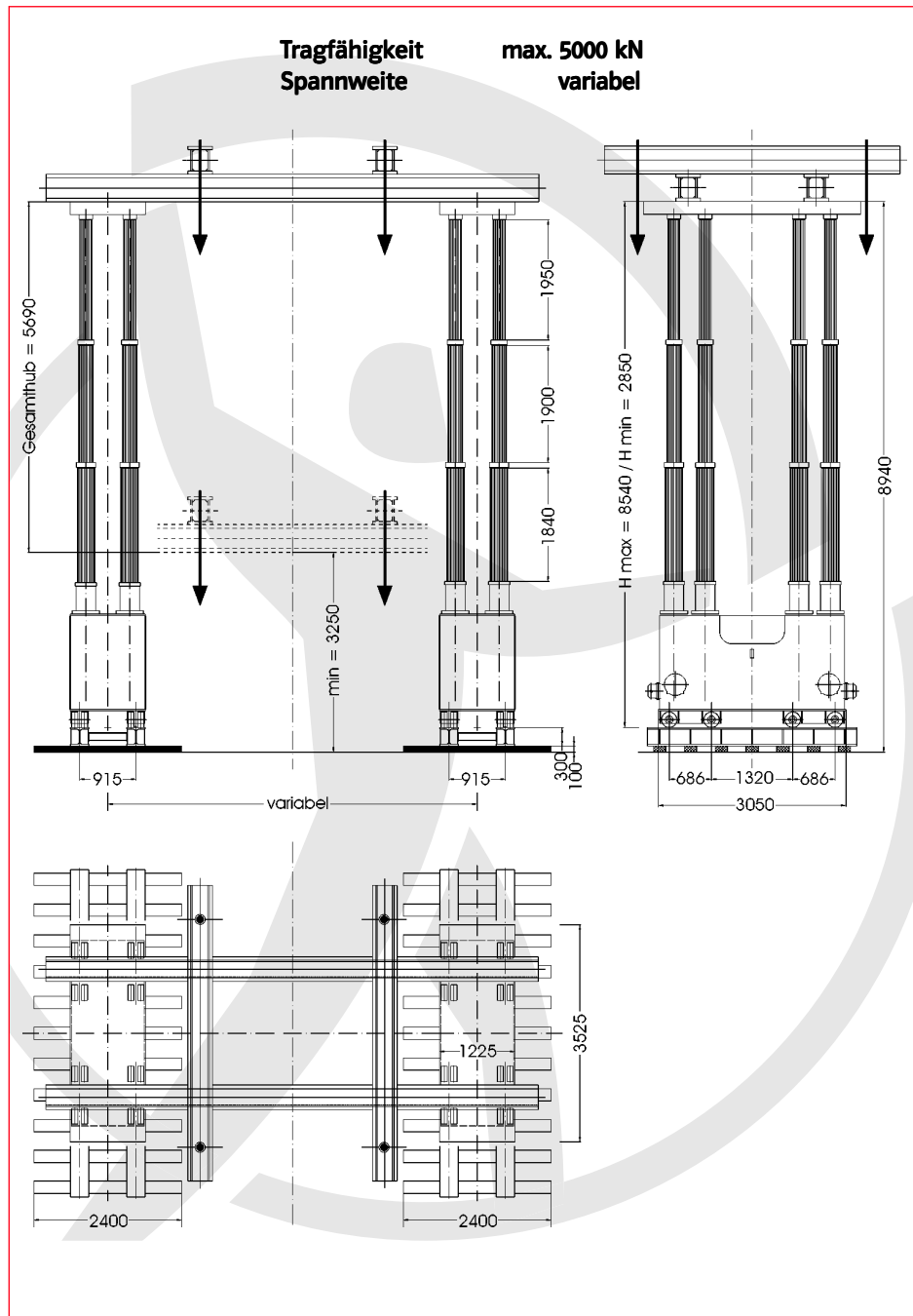

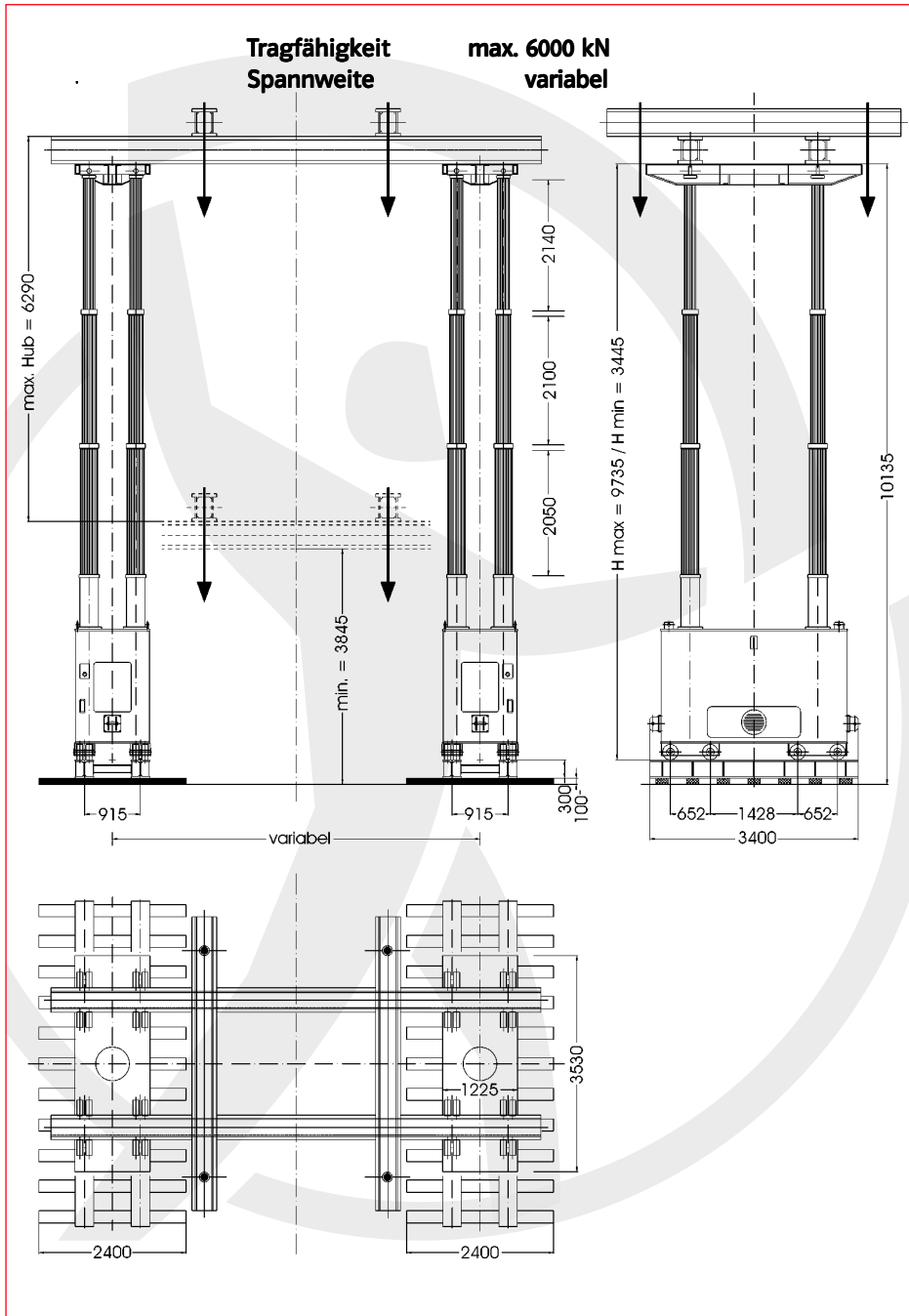

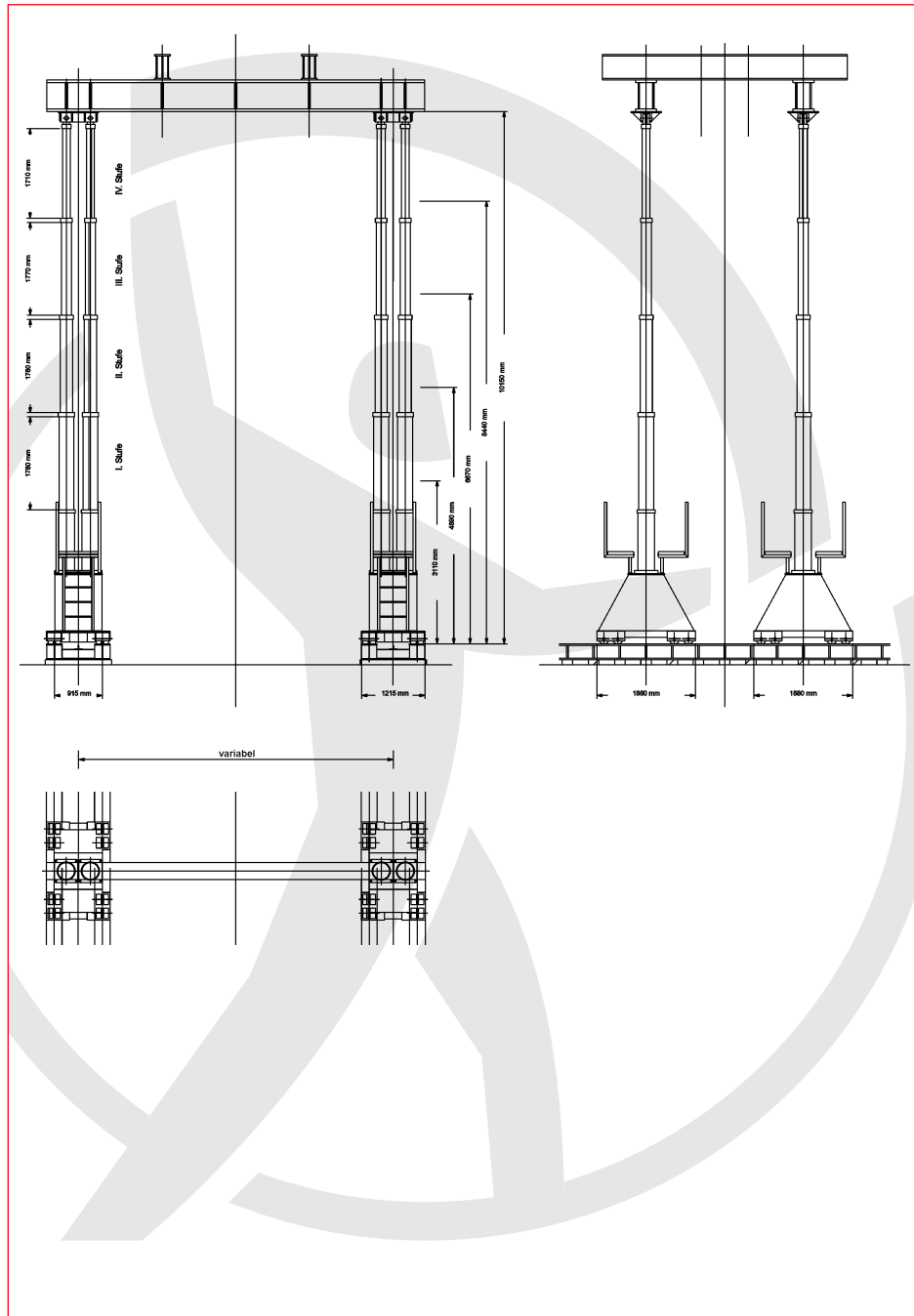

Infoline 01805 - 75 85 99





Basisversion

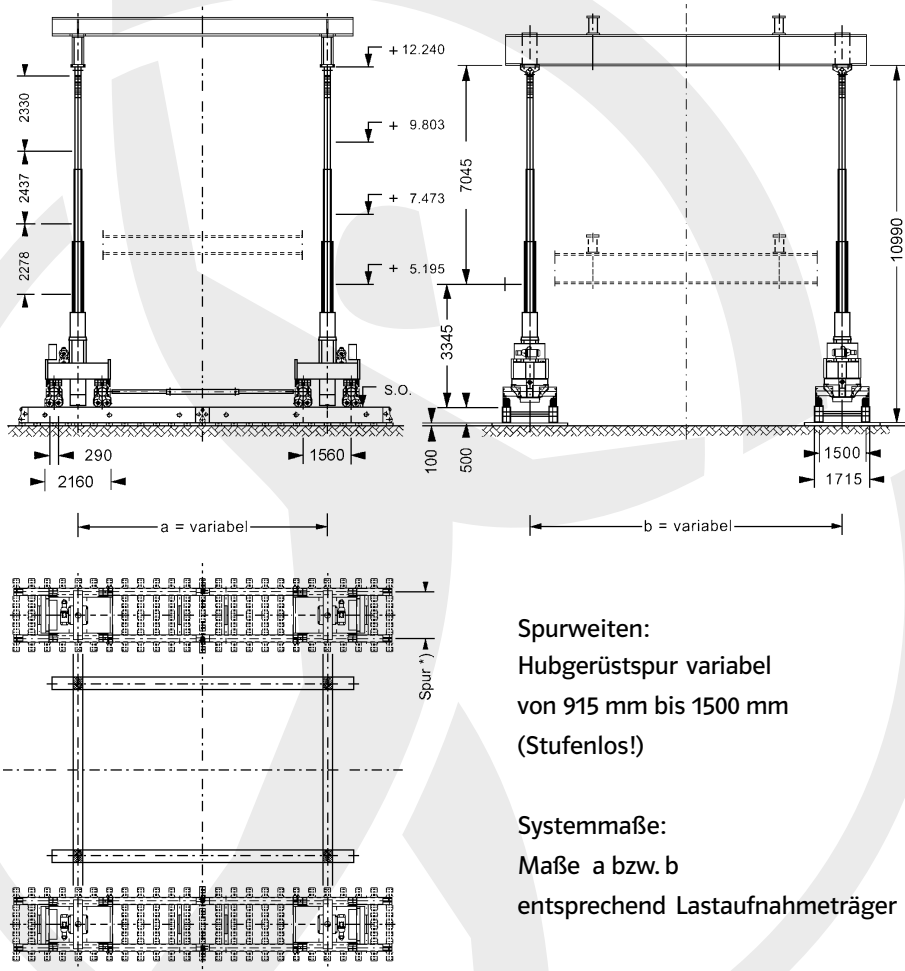

Spurweiten:
Hubgerüstspur variabel
von 915 mm bis 1500 mm
(Stufenlos!)

Systemmaße:
Maße a bzw. b
entsprechend Lastaufnahmeträger

Version mit Zwischenstück (1250 mm)

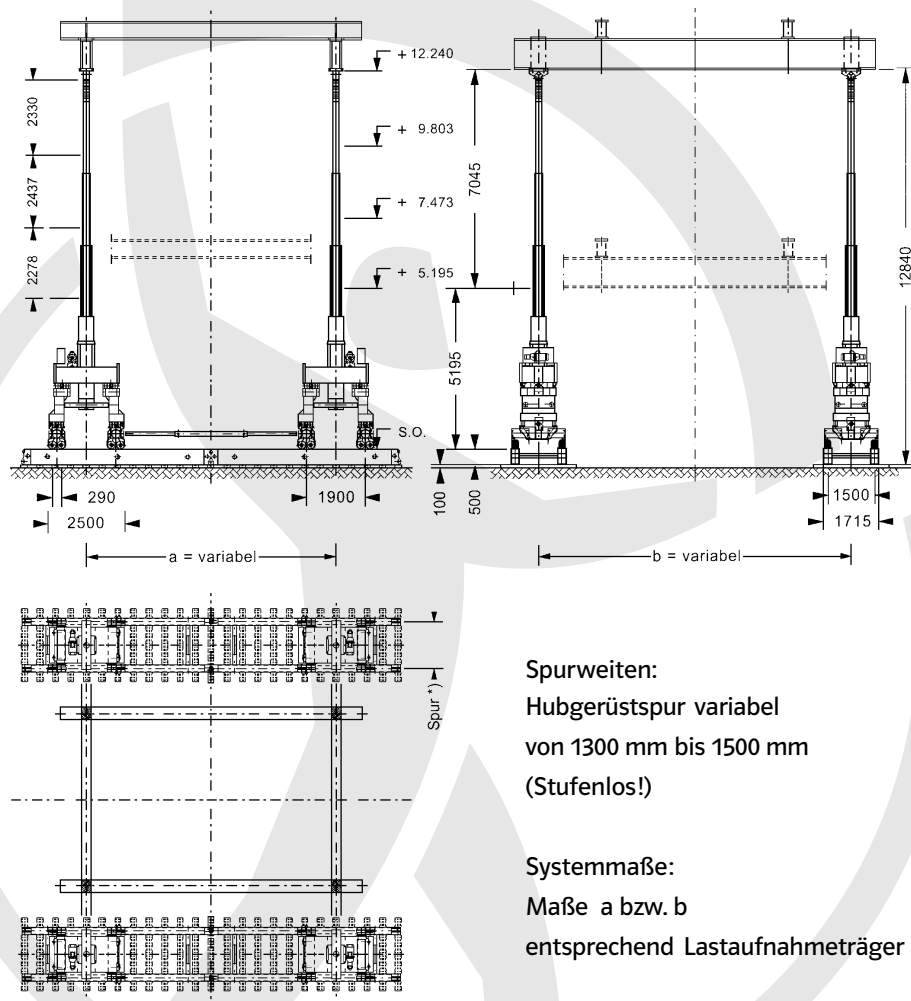



Basisversion

**Max. Rüstzustand
inkl. Zwischenstück 1250 mm und
mech. Zylinderverlängerung 600 mm**

